

Part Number: PT278-60161

Kit Contents

Item #	Quantity Req'd.	Description
1	2	Roof Rack Crossbar Assembly
2	1	Cover, LH Front
3	1	Cover, LH Rear
4	1	Cover, RH Front
5	1	Cover, RH Rear
6	1	Hardware Bag

Hardware Bag Contents

Item #	Quantity Req'd.	Description
1	1	Torque Wrench
2	1	Lock Key
3	1	Owner's Manual
4	2	Load Labels

Additional Items Required For Installation

Item #	Quantity Req'd.	Description
1		
2		
3		

Conflicts

Panoramic sunroof

Recommended Tools

Personal & Vehicle Protection	Notes
Safety Glasses	
Safety Gloves	
Blankets or Similar	
Wrist & Belt Buckle Protection	
Special Tools	Notes
Installation Tools	Notes
Torque Wrench	0-75 lbf-in
13mm Socket	
Ratchet	
Special Chemicals	Notes

General Applicability

All LX models with OE side rails and without panoramic sunroof
--

Recommended Sequence of Application







Item #	Accessory
1	
2	
3	

*Mandatory

Vehicle Service Parts (may be required for reassembly)

Item #	Quantity Req'd.	Description
1	1	Key w/ Manual Part # PT278-48161-AA
2	1	Cover w/ Lock (Front) Part # PT278-48160-AB
3	1	Cover w/ Lock (Rear) Part # PT278-48160-AC
4	1	Inner Clamp Part # PT278-48160-AD
5	1	Bolt with Clip Part # PT278-48160-AE
6	1	Torque Wrench Part # PT278-48140-TT

Legend

	STOP: Damage to the vehicle may occur. Do not proceed until process has been complied with.
	OPERATOR SAFETY: Use caution to avoid risk of injury.
	CAUTION: A process that must be carefully observed in order to reduce the risk of damage to the accessory/vehicle and to ensure a quality installation.
	TOOLS & EQUIPMENT: Used in Figures calls out the specific tools and equipment recommended for this process.
	REVISION MARK: This mark highlights a change in installation with respect to previous issue.
	SAFETY TORQUE: This mark indicates that torque is related to safety.

Care must be taken when installing this accessory to ensure damage does not occur to the vehicle. The installation of this accessory should follow approved guidelines to ensure a quality installation.

These guidelines can be found in the "Accessory Installation Practices" document.

This document covers such items as:-

- Vehicle Protection (use of covers and blankets, cleaning chemicals, etc.).
- Safety (eye protection, rechecking torque procedure, etc.).
- Vehicle Disassembly/Reassembly (panel removal, part storage, etc.).
- Electrical Component Disassembly/Reassembly (battery disconnection, connector removal, etc.).

Please see your Lexus dealer for a copy of this document.

1. Install the Front Cross Bar.

⚠ NOTE: Be careful during installation to prevent scratching of the roof rails and the vehicle roof. Cover the vehicle roof with a blanket.

- (a) The front cross bar has a "FRONT" sticker located on the center of the bar (Fig. 1-1).

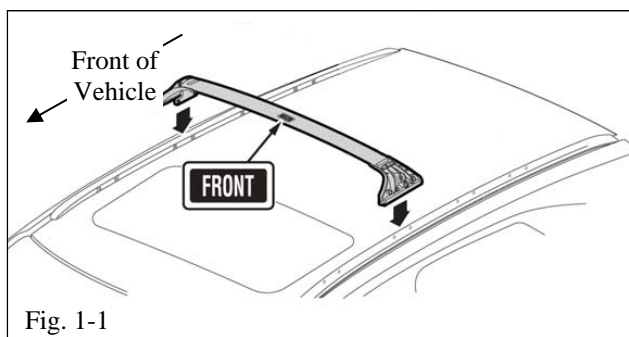

- (b) **If necessary**, use a 13mm socket & ratchet to loosen the clamp (Fig. 1-2). Open the clamp to 2-1/4" to minimize the potential of scratching the side rails (Fig. 1-3).

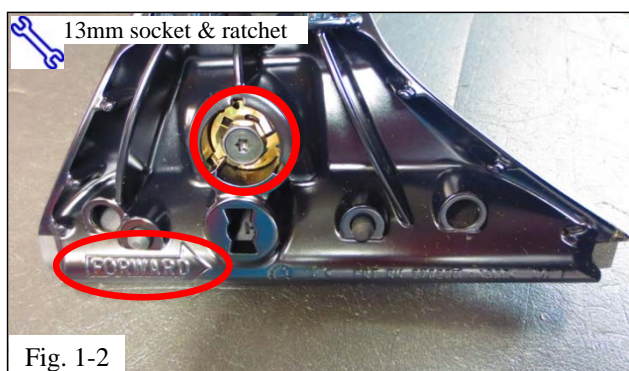

- (c) Determine the correct cross bar orientation by locating "FORWARD" molded on the surface of the supports (See Fig. 1-2).



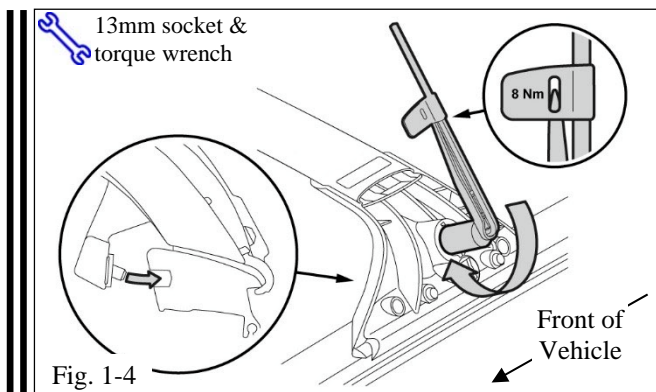

- (d) Align the pins of the driver side clamp/support sub-assembly with the second set of roof rail mounting holes from the front of the vehicle (Fig. 1-4).
- (e) Align the pins of the passenger side clamp/support sub-assembly with the opposite roof rail mounting holes. The clamp/support sub-assembly may require adjustment inward or outward for a snug fit.

⚠ NOTE: Ensure the pads located underneath the supports are flush to the rail for proper assembly.

- (f) While holding the clamp with the pins aligned into the rail holes, use a torque wrench (traditional or supplied) to torque each main attaching screw to 8 N•m (71 in•lbf). If using the supplied wrench, apply force until the needle is in the center of the flag window (Fig. 1-4).

⚠ Torque: 8 N•m (71 in•lbf)

- (g) Re-torque each main attaching screw a second time in the same order as Step 1(f).

⚠ Torque: 8 N•m (71 in•lbf)

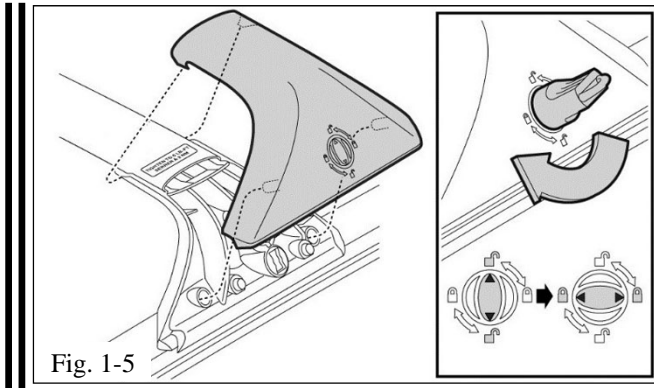

(h) Assemble the cover onto the support.

(1) Align the ball and socket joint and apply a slight force until the cover snaps into place.

(2) Slide the top of the cover around the bar.

(i) Neatly open the bag & use the supplied key to turn the lock 90° to the locked position (Fig. 1-5).

2. Install the Rear Cross Bar.

(a) Determine the correct cross bar orientation by locating “FORWARD” molded on the surface of the supports.

(b) **If necessary**, use a 13mm socket & ratchet to loosen the clamp. Open the clamp to 2-1/4” to minimize the potential of scratching the side rails.

(c) Align the pins of the driver side clamp/support sub-assembly with the last set of roof rail mounting holes from the front of vehicle (Fig. 2-1).

(d) Align the pins of the passenger side clamp/support sub-assembly with the opposite roof rail mounting holes. The clamp/support sub-assembly may require adjustment inward or outward for a snug fit.

⚠ NOTE: Ensure the pads located underneath the supports are flush to the rail for proper assembly.

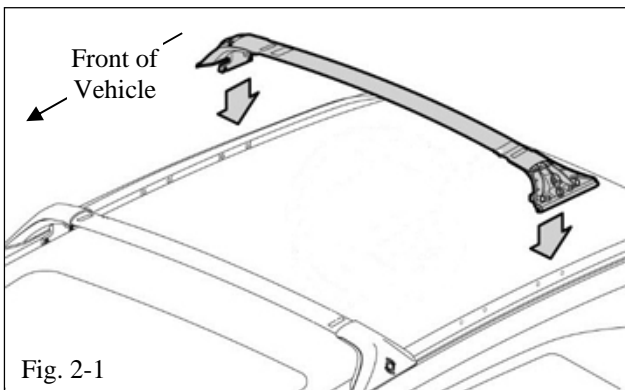

- (e) While holding the clamp with the pins aligned into the rail holes, use a torque wrench (traditional or supplied) to torque each main attaching screw to 8 N•m (71 in•lbf). If using the supplied wrench, apply force until the needle is in the center of the flag window.

⚠ Torque: 8 N•m (71 in•lbf)

- (f) Re-torque each main attaching screw a second time in the same order as Step 2(e).

⚠ Torque: 8 N•m (71 in•lbf)

- (g) Assemble the cover onto the support.
 - (1) Align the ball and socket joint and apply a slight force until the cover snaps into place.
 - (2) Slide the top of the cover around the bar.
- (h) Use the supplied key to turn the lock 90° to the locked position.

3. Install the Load Labels.

- (a) Remove the load labels from the hardware package.
- (b) Remove one of the load labels from the protective backing.
- (c) Orient the label so that the text is legible.
- (d) Place the label on the right hand side roof rail, 253mm from the rear crossbar's front mounting location hole (Fig. 3-1).
- (e) Properly wet-out the adhesive by applying force from one end of the load label to the opposite end of the load label.

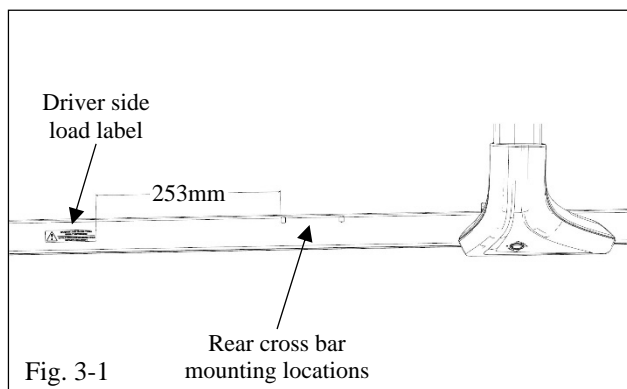



Fig. 3-1

- (f) Remove the second load label from the protective backing.
- (g) Orient the label so that the text is legible.
- (h) Place the label on the left hand side roof rail, 253mm from the rear crossbar's front mounting location hole.
- (i) Properly wet-out the adhesive by applying force from one end of the load label to the opposite end of the load label.

4. Finish the Installation.

-  (a) Place the cross bar installation instructions, torque wrench and key inside the bag.
- (b) Place the bag with contents into vehicle's glove box.

Checklist - these points **MUST** be checked to ensure a quality installation.

<u>Check:</u>	<u>Look For:</u>
<p><u>Accessory Function Checks</u></p> <ul style="list-style-type: none">  <input type="checkbox"/> Inspect bolt torque <input type="checkbox"/> Ensure cross bars are secure and in correct position. <input type="checkbox"/> Cross bar installation instructions/torque wrench/key <input type="checkbox"/> Load label <input type="checkbox"/> Cross bar gaps <input type="checkbox"/> Cross bar orientation 	<p>Cross bar support bolt: 8 N•m (71 in•lbf)</p> <p>Cross bars should have snug fit to rail.</p> <p>Installation instructions, torque wrench and key are inside glove box.</p> <p>Ensure the load labels are installed on the rail.</p> <p>Protective pads should have less than 1.0mm gap to rail.</p> <p>Ensure cross bars FORWARD arrow is facing the front of vehicle.</p>
<p><u>Vehicle Function Checks</u></p> <ul style="list-style-type: none"> <input type="checkbox"/> <input type="checkbox"/> 	
<p><u>Vehicle Appearance Check</u></p> <ul style="list-style-type: none"> <input type="checkbox"/> After accessory installation and removal of protective cover(s), perform a visual inspection. 	<p>Ensure no damage (including scuffs and scratches) was caused during the installation process.</p> <p>(For PPO installations, refer to TMS Accessory Quality Shipping Standard.)</p>